

## Key Features:

- Heavy duty cable, umbilical and riser cutter for use in severe working conditions
- Hydraulically operated anvil for easy ROV deployment
- Robust plated steel construction
- All steel components are electroless nickel plated to resist corrosion
- Long blade life ensures that tool maintenance is kept to a minimum
- Optional intensifier panel is available

## Webtool™ HCV270

### Cutters and Grinders

The cutter is intended for use on Coflexip type riser and will cut hose up to 270mm diameter. It may be used on alternative materials, such as electrical power or communication cables, up to a maximum of 200mm diameter.

Where small diameters are to be cut, effort should be made to place the material centrally along the anvil to minimise any offset loading. The cutter is not designed to cut large diameter wire rope.



# Webtool™ HCV270

Cutters and Grinders



## Specifications

<b>Dimensions</b>	Height	1143mm
	Width	883mm
<b>Weight</b>	Weight in air	352Kg
	Weight in water	324Kg
<b>Hydraulics</b>	Max input pressure (main cylinder)	690 Bar
	Max input pressure (anvil cylinder)	210 Bar
<b>Cutting capacity</b>	Maximum Ø270mm	

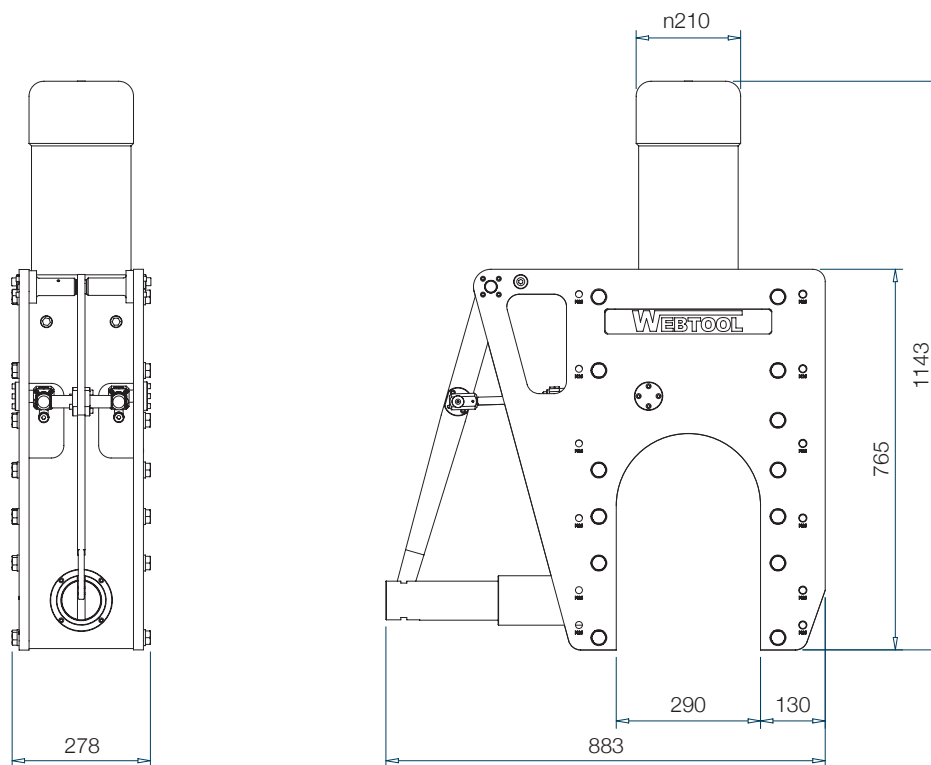

## System Components

270mm hydraulic cutter	Anvil hydraulic hose set	
Operating manual		
Transit case		
Spare blade		