

## Key Features:

- Heavy duty cable, umbilical and riser cutter for use in severe working conditions
- Hydraulically operated anvil for easy ROV deployment
- Lightweight aluminium construction
- Long blade life ensures that tool maintenance is kept to a minimum
- Optional intensifier panel is available

## Webtool™ HCV100

### Cutters and Grinders

**The HCV100 is a lightweight double acting cutting tool primarily intended for use on umbilical cable and hose and will cut up to 100mm diameter.**

It may be used on alternative materials, such as electrical power or communication cables, again up to a maximum of 100mm diameter. It may be mounted on an ROV or manipulator arm. Where small diameters are to be cut, every effort should be made to place the material centrally along the anvil to minimise offset loading.

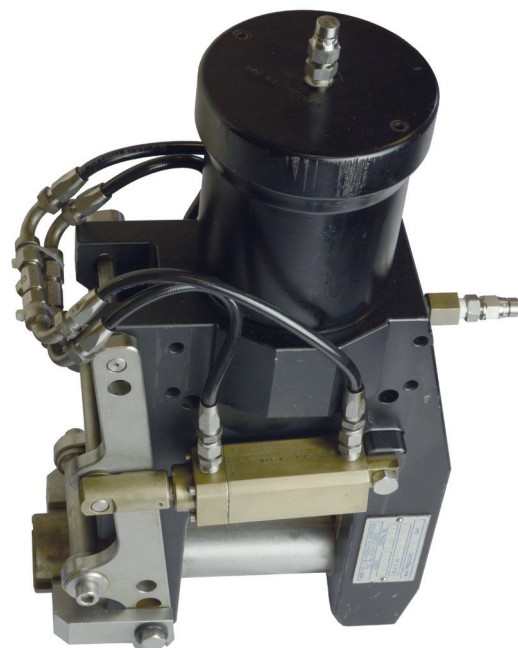

# Webtool™ HCV100

Cutters and Grinders



## Specifications

<b>Dimensions</b>	Height	470mm
	Width	422mm
<b>Weight</b>	Weight in air	29.5Kg
	Weight in water	22Kg
<b>Hydraulics</b>	Max input pressure (main cylinder)	690 Bar
	Max input pressure (anvil cylinder)	210 Bar
<b>Cutting capacity</b>	Maximum Ø100mm	

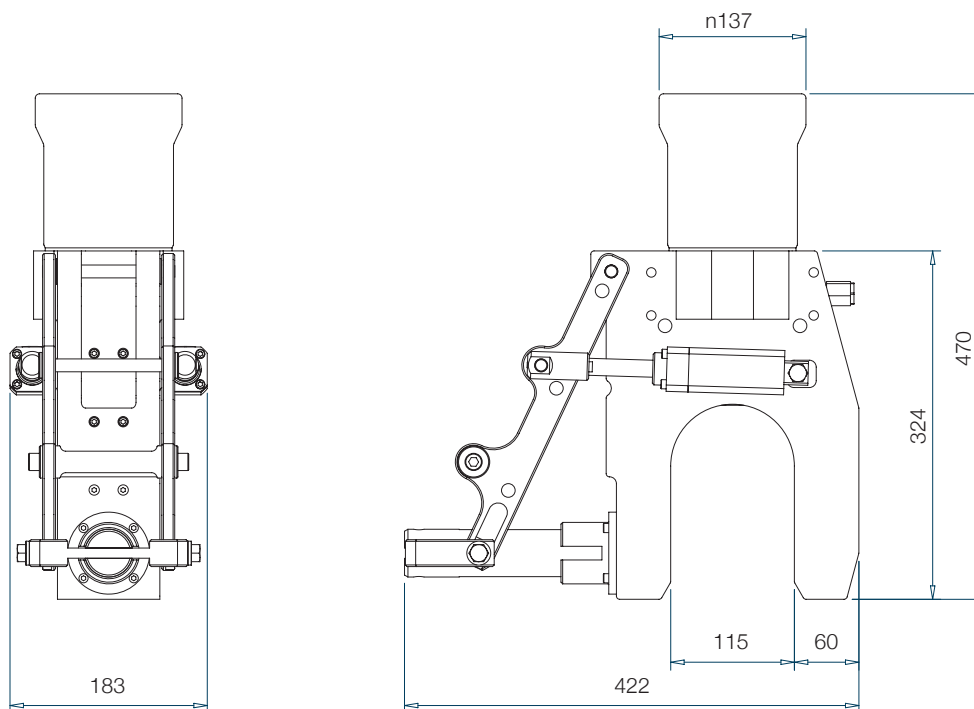

## System Components

100mm hydraulic cutter	Anvil hydraulic hose set	
Operating manual		
Transit case		
Spare blade		