

# SeaKing 700 Series

## Integrated Oceanographic Sensor Suite



Integrate into a SeaKing network for accurate bathymetric data collection.

The SeaKing Bathymetric System operates as a stand-alone instrument, or a single sub-sea node on the SeaKing network and shares the same twisted pair wiring as the SeaKing Profiler or SeaKing Sonar. Vehicle integration is very simple since only a single pair of conductors are required on the ROV.

The SeaKing Bathymetric system comprises up to four high resolution sensors - a depth sensor, conductivity probe, temperature probe and the PA500 altimeter.

Two standard configurations are available, either as a pressure only package (SeaKing 701) or as a pressure, conductivity and temperature package (SeaKing 704).

The sensors form an integrated package, however, the PA500 altimeter is on a cable and can be mounted separately on the ROV which allows positioning of the individual sensors away from areas of masking or disturbance such as vehicle structure or thruster wash.

For the SeaKing 704 full water column profiling is achieved by dynamically modifying a lookup table which contains all measured parameters versus depth. This table may be stored by the surveyors and re-loaded as required.

### Benefits

- Configurable design
- Integrated compact unit
- Seamlessly combine with SeaKing network

### Features

- Real-time monitoring of conductivity
- Real-time monitoring of temperature
- 700m to 4000m depth ratings available
- Robust and proven design
- Reliable and accurate sensors

### Applications

- Pipeline, site and route surveys
- Echosounder surveys

# Specification

SK701 with PA500 altimeter

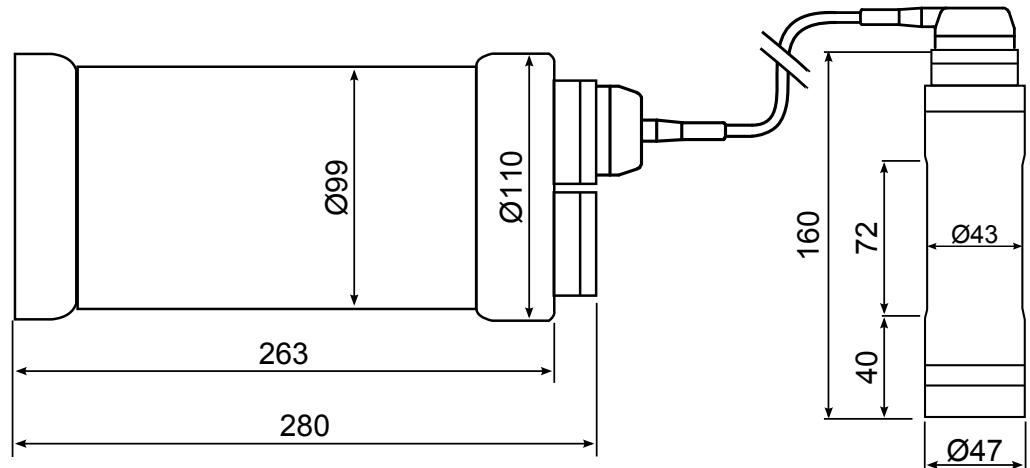

SK704 with PA500 altimeter

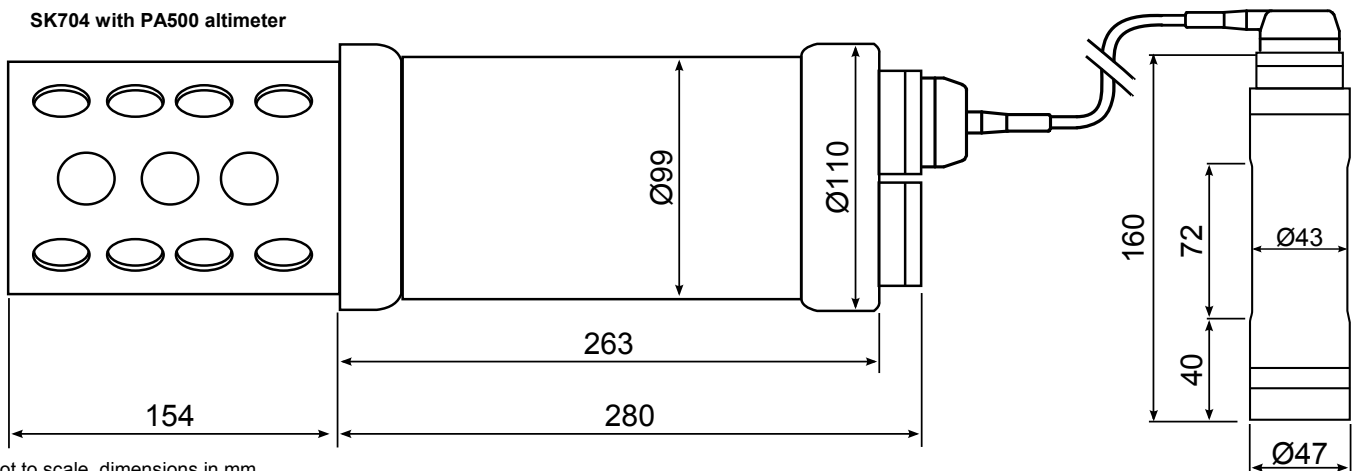

Not to scale, dimensions in mm

Altimeter	
Make	Tritech International
Type	PA500
Weight in air	1.15kg
Weight in water	0.8kg
Frequency	500kHz
Beamwidth	6° conical
Range	0.3 to 50m
Resolution	1mm
Material	Stainless steel (titanium 6Al4V optional)

System - physical	
Weight in air	Aluminium: 3.5kg (4.2kg with CT probe)
Weight in water	Aluminium: 1.5kg (2.1kg with CT probe)
Materials	Anodised aluminium alloy (6Al4V titanium alloy or stainless steel optional)

System - electrical	
Power consumption	24 -28V DC at 8VA (nominal)
Communications	ARCNET, RS232

Depth Sensor	
Make	Paroscientific Digiquartz
Repeatability	0.01% FSD
Hysteresis	0.015% FSD
Drift	0.015% FSD

Temperature Sensor	
Make	Teledyne RDI (Falmouth Scientific)
Type	Platinum Resistance
Range	-5 to 25°C
Accuracy	±0.05°C
Drift	±0.005°C per month

Conductivity Sensor	
Make	Teledyne RDI (Falmouth Scientific)
Range	0 to 6.5 S·m <sup>-1</sup>
Accuracy	±2.0mS·m <sup>-1</sup>
Drift	±0.5mS·m <sup>-1</sup> per month

Specifications subject to change according to a policy of continual development.

Document: 0367-SOM-00002, Issue: 02

Marketed by:

**Tritech International Ltd**  
 Peregrine Road, Westhill Business Park  
 Westhill, Aberdeenshire, AB32 6JL  
 United Kingdom  
 sales@tritech.co.uk  
 +44(0)1224 744 111

