

The Aquadopp current meter is designed for any body of water, whether ocean, estuary, lake or river. Current meters measure the water current velocity in a single volume. The Aquadopp current meter is small in size but an extremely powerful sampling system that allows it to be used in a variety of applications.

## Aquadopp<sup>®</sup> Current Meter

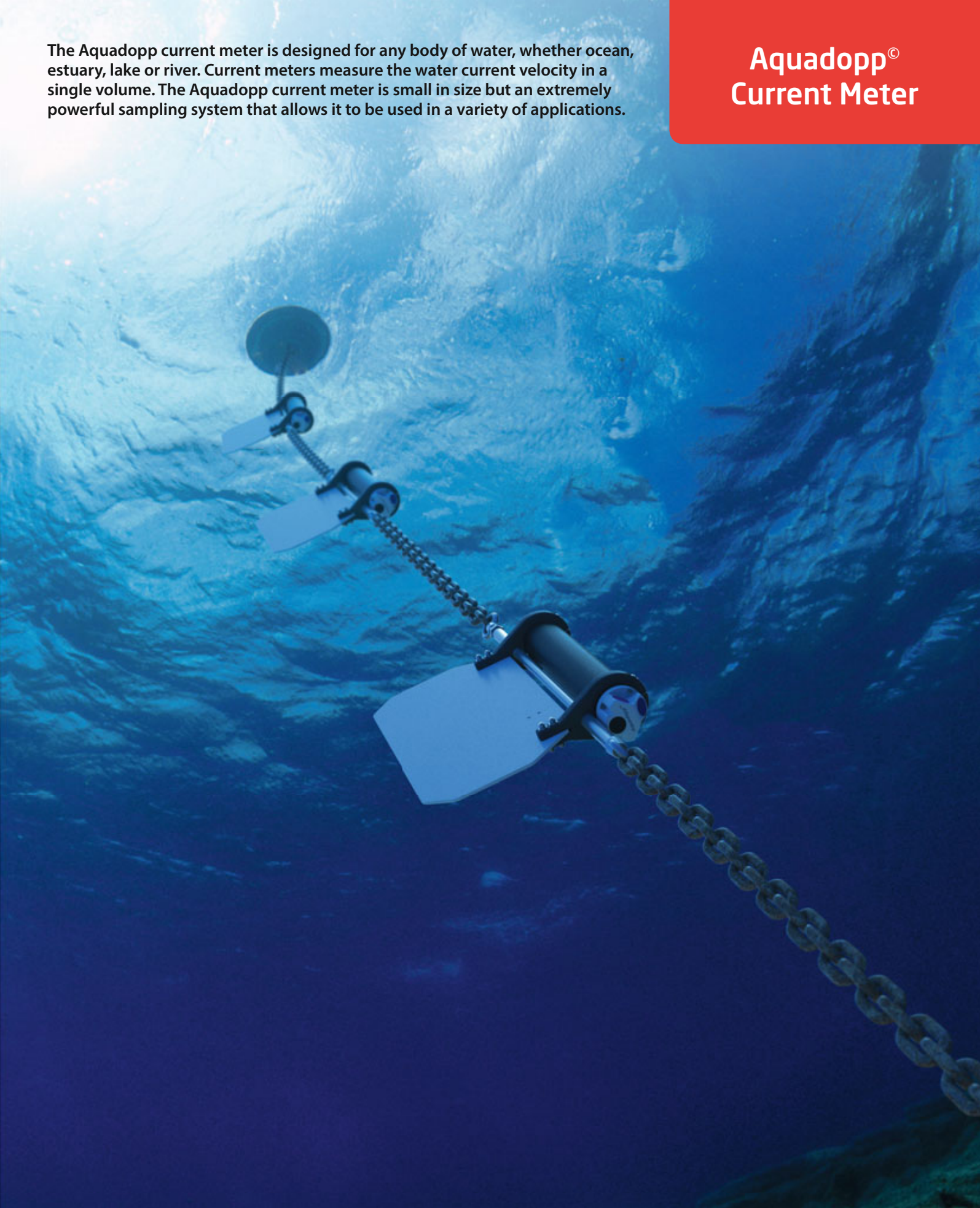

CURRENT AND WAVE MEASUREMENTS IN THE OCEAN, LAKE AND LABORATORY



Nortek AS  
Vangkroken 2  
1351 Rud, Norway  
Tel: +47 6717 4500  
Fax: +47 6713 6770  
E-mail: [inquiry@nortek.no](mailto:inquiry@nortek.no)



[www.nortek-as.com](http://www.nortek-as.com)  
True innovation makes a difference

# AQUADOPP CURRENT METER

The most versatile 3D ocean current meter available

The Aquadopp® is probably the most versatile single-point current meter on the market and has become the industry's most trusted model since its introduction in 1999. The Aquadopp® is in use by scientists and engineers all over the world, from the Arctic to the Equatorial Pacific. It is deployed in environments ranging from rivers to deep ocean trenches. The Aquadopp's utility stems from its cost-effective yet robust design requiring low maintenance and no recalibration.

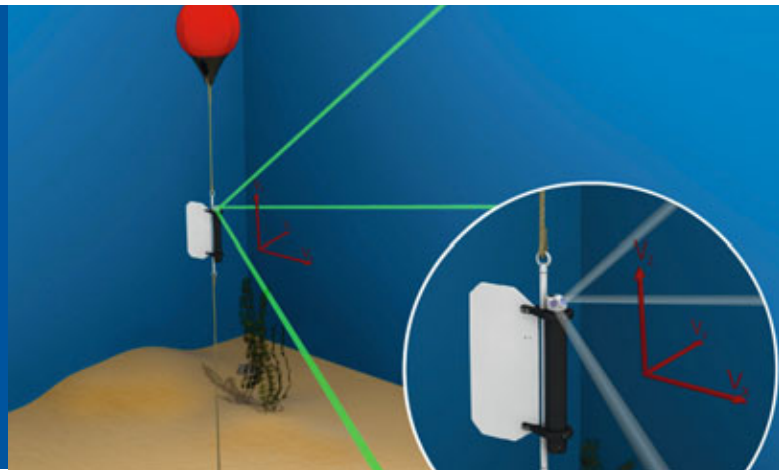

## The Aquadopp® advantages

The Aquadopp® has several significant advantages when compared to other open ocean current meters:

- No calibration necessary; no zero-point drift over time
- Low power consumption for long deployments
- All plastic and titanium parts eliminate corrosion
- No moving parts that can be blocked or damaged
- Effective directional wave gauge
- Remote sampling volume away from the mounting structure
- Small and light weight (less than 3kg)

## The Aquadopp® Design

The Aquadopp® is comprised of 2 MHz acoustic transducers that transmit short bursts of sound into the water. The sound propagates along narrow acoustic beams and is scattered by small particles or zooplankton suspended in the water.

The echo that reaches the transducers is analyzed for change in frequency (Doppler shift) and water velocity is calculated along each of the acoustic beams. By combining the velocities with the exact beam geometry, either 2D (2 beams) or 3D (3 beams) velocity is calculated and recorded on the internal recorder or reported online.

In addition to velocity measurements, the Aquadopp contains compass and tilt sensors making it possible to measure the orientation of the instrument.

## Classical Applications

From the ocean to rivers and the equator to the poles, the Aquadopp® delivers unmatched functionality.



### Ocean Moorings

The Aquadopp® with its low maintenance and recalibration needs is ideal for long term deployments. Either clamp it directly to a mooring line or mount it on the Nortek Aquafin or AquaClamp.



### Buoys

To measure surface currents, the Aquadopp® can be mounted directly onto surface buoys. The Aquadopp® Surface Current Meter transducer configuration is designed to measure near-surface currents with three acoustic beams directed in a horizontal plane just below the surface.



### Fixed Mountings

Whether fixed to an offshore structure, piling, or bottom frame, for every mounting structure there is a corresponding Aquadopp® transducer head configuration that allows high quality measurements to be gathered.

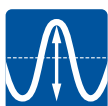

### Wave Height

The Aquadopp® can measure wave height, period, and direction using PUV processing. With PUV processing, 2D velocity (U and V) is combined with pressure (P) measurements to provide a full directional spectra solution.



### Rivers

In rivers, channels, and harbors, the Aquadopp® can be side-mounted on a wall to monitor the 2-D flow, avoiding sedimentation on the sensor head.



### Deep Water

The deep water Aquadopp® current meters can be used anywhere in the ocean up to 6000 m depth. Both the 6000 m and 3000 m models have demonstrated outstanding performance in low scatter conditions.

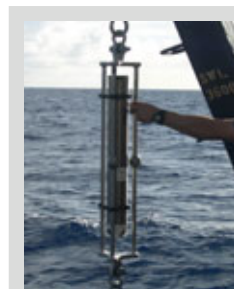

### Passing the deep water test

As part of a program aimed at developing long duration subsurface moorings, Wood Hole Oceanographic Institution (WHOI) tested several modern acoustic current meters during the period 2000 to 2005.

The work focused on the fidelity of the speed measurements and showed the challenge of using backscattering acoustic systems in the clear, deep ocean.

Over the course of the test period, Nortek continually improved the Aquadopp construction and with prototype 3, which reflects the design of the current generation deep water Aquadopp current meters, the instrument bias in deep water was reduced to a level that was no longer significant.

*"Performance of a new generation of acoustic current meters". Hogg, Nelson G.; Frye, Daniel E., Journal of Physical Oceanography (2007)*

Is your application not listed? Contact Nortek! We look forward to working with you to tailor the most versatile 3D current meter on the market to your unique research.



## Configuration

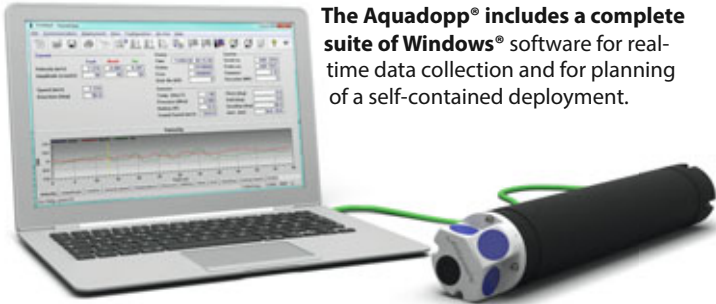

The Aquadopp® includes a complete suite of Windows® software for real-time data collection and for planning of a self-contained deployment.

It is also designed to be integrated with third party controllers using the RS-232/RS-422 interface (binary or ASCII output).

The Aquadopp® can be used in real-time applications, but also comes standard with an internal recorder, batteries and a highly sophisticated power management network that makes it the system of choice for multi-year self-contained deployments.

The Aquadopp® can be configured to measure more than velocity. The system electronics of the Aquadopp® have integrated temperature and pressure sensors, as well as two analog input channels allowing for integration with 3rd party sensors.

In addition to regular data collection configurations, the Aquadopp® can be set to Diagnostic Mode. Diagnostic mode, a unique feature to the Aquadopp®, collects raw velocity and engineering data at 1Hz for a specified duration and interval. Originally introduced to learn more about mooring motion, it quickly proved popular for wave data as well. Data with such a fine temporal resolution not only provides a useful QA/QC tool, but allows the study of phenomena on very short time scales.

## Deep Water Models

The 3000 m and 6000 m Aquadopp® have all the capabilities of the standard Aquadopp® (300 m) but are designed for deployments in the deep ocean.

The 6000 m Aquadopp® is the “big brother” in the line of Aquadopp® models. The all-titanium mechanical housing of the 6000 m model with non-corroding materials creates a rugged design built to last at great ocean depths. Though built from grade 2 Titanium, the instrument only weighs ~8kg.

The 3000 m model is made of Delrin and lined internally with a metal cylinder. The innovative 3000 m design is lighter and more affordable than the 6000 m model; providing a good alternative for intermediate waters.

### Measuring currents in the deep ocean is a challenge.

In the deep ocean, there are fewer particles than in the upper 500 m of the water column, creating a challenge for instruments that depend on acoustic backscatter. Considerable work has been done with the Aquadopp® to understand the factors that affect acoustic signal strength, improve the sensitivity of the returned echo, and produce high quality data.



## PUV waves

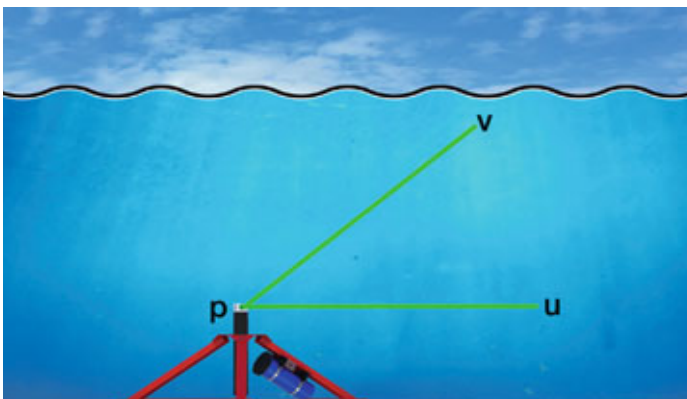

The Aquadopp® can be configured to collect directional wave data at the same time as it measures the mean current. Nortek provides postprocessing software, QuickWave, that uses the PUV method to calculate the full directional wave spectra from the raw data.

As a wave sensor, the Aquadopp® requires extra internal memory, but it remains the most cost-effective PUV instrument in the market.

The PUV method is based on linear wave theory. Pressure is used to estimate non-directional parameters (height and period), and the combination of the pressure and the two horizontal velocity components U and V are used to calculate the wave direction.

## Transducer Head Configurations

The Aquadopp® current meter is typically constructed with either the "Symmetric" or "Mooring" transducer head configuration. Both geometries provide outstanding 3-component (East, North, Up) observations of velocity.



### Symmetric

Symmetric transducer head geometry projects three acoustic beams symmetrically up and away from the instrument. The beams are separated by 120 degrees around the circumference of the instrument and are angled 65 degrees from the vertical.



### Mooring

Mooring transducer head geometry projects two acoustic beams in a plane horizontally away from the instrument. These two beams are separated by 90 degrees around the circumference. The third beam projects at an angle 45 degrees from the vertical.



### Custom

Nortek offers the ability to craft custom transducer head geometries to meet specific velocity measurement needs. Contact Nortek to learn about what special transducer heads have already been developed and discuss your specific project requirements.

## Inline Frames



### Aquafin

The Aquafin is designed for connecting an Aquadopp® current meter to a mooring line. It shackles into the mooring line and allows the Aquadopp® to swivel freely so that its beams always look into undisturbed flow. Choose non-magnetic stainless steel or titanium for mooring loads of 1500 kg.



### Deep water mounting systems

A variety of mounting systems have been designed for deep water moorings. Some of them clamp directly to the mooring line and some require the line to be cut. The systems have different load bearing strength (generally from 750 to 4500 kg) and are made from different materials (stainless steel or titanium). Most the systems are machined locally and more information is available from your local Nortek representative.

## Inductive Modem (IM)

### Broadcasting real time data with the Aquadopp inductive modem option

An inductive modem allows real time data to be transmitted through a jacketed, steel cable using sea water as the return ground. This means that real time data can be sent over long distances using robust cables that do not contain individual signal wires.

The mechanical design of the Aquadopp® shallow water (IM400) and deep water current meter (IM6000) have been modified to include a clamping system with electric coils that mounts directly to the unbroken mooring line. The process of sending data includes three steps:

- The Aquadopp stores data both to the internal recorder and to the inductive modem module.
- The Seabird surface modem, usually mounted in a buoy, prompts the Aquadopp to transmit the last data.
- The Seabird Inductive Modem Module mounted in the Aquadopp housing sends the data through the coils clamped around the metal mooring line and up to the surface modem.

The inductive modem is addressable and a single mooring line can include a large number of Aquadopp IM current meters and Seabird IM sensors.

Nortek has also tested communication with the RBR inductive modem, which can be used to transmit data from most other low bandwidth Nortek instruments such as the AWAC and the Aquadopp profiler.

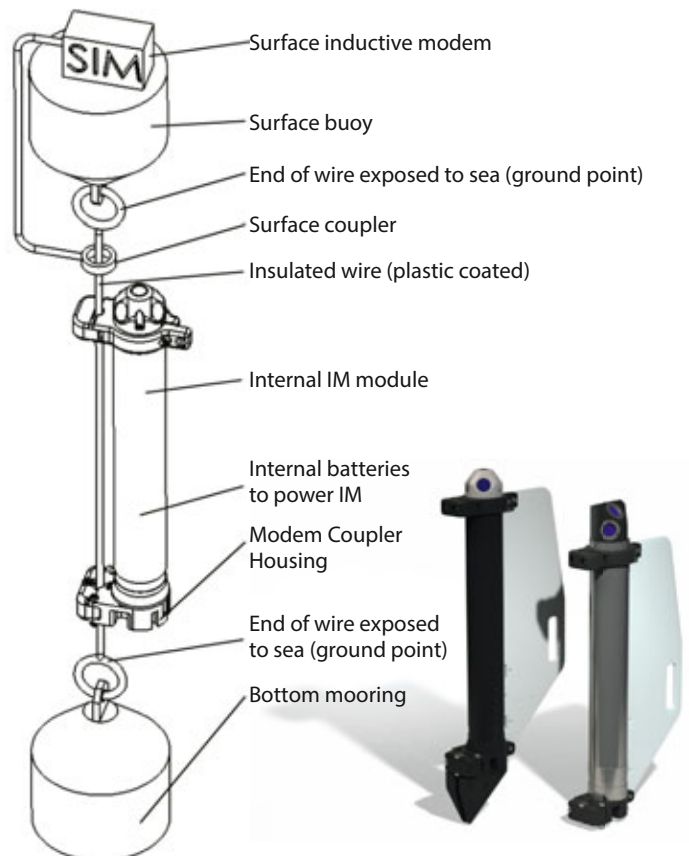

300m

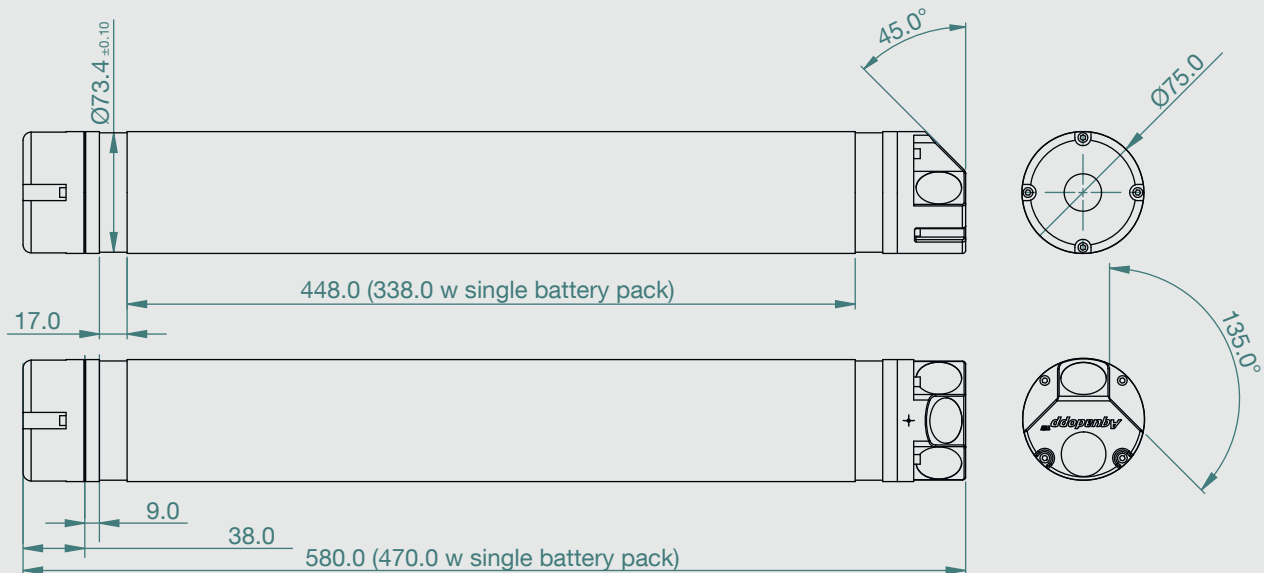

3000m

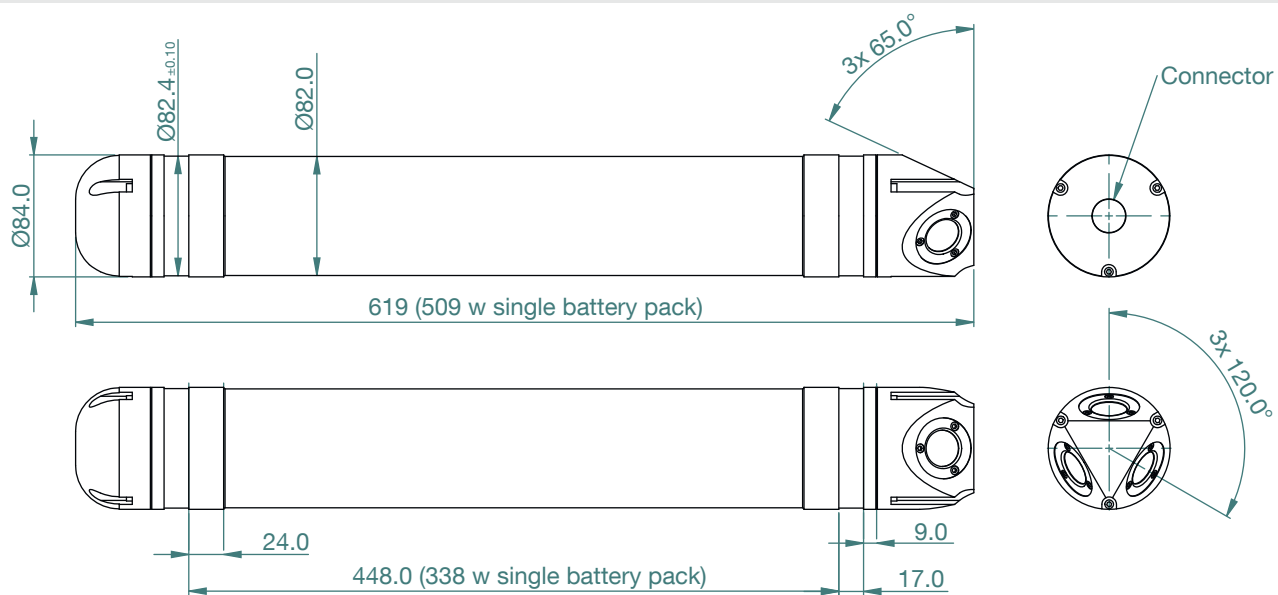

6000m

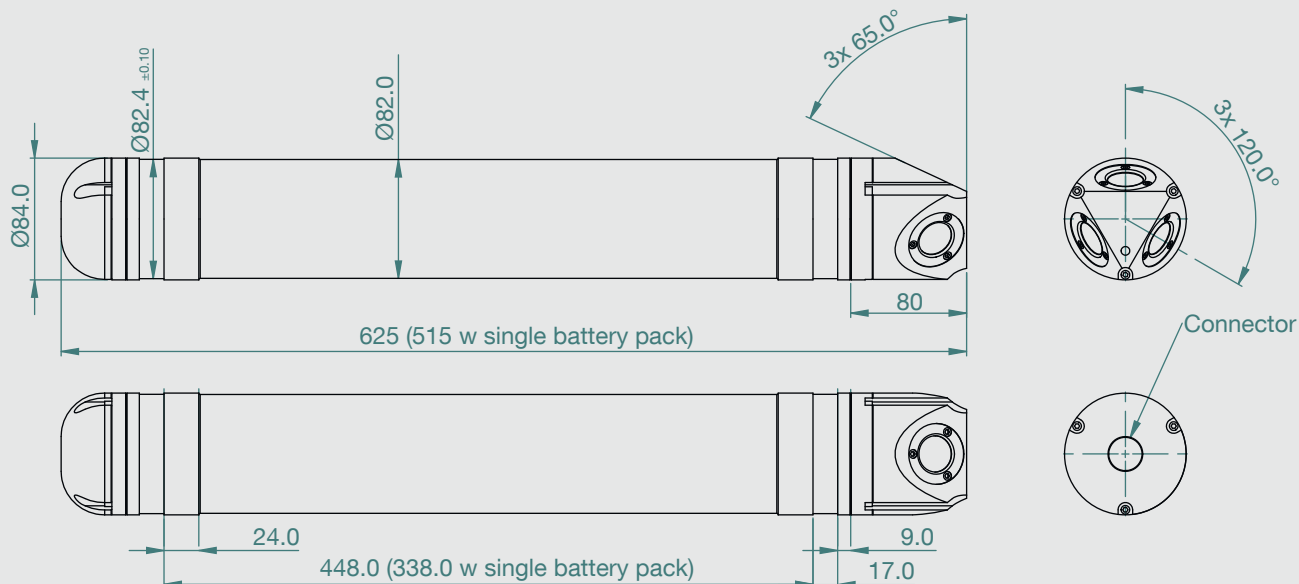

Water velocity measurement			
	300m	3000m	6000m
Range:	±5m/s*	±3m/s*	±3m/s*
Accuracy (of measured value ± 0.5m/s):	1%	1%	1%
Maximum sampling rate (output):	1Hz, 4Hz on request	1Hz	1Hz
Internal sampling rate:	23Hz	23Hz	23Hz

\*) Inquire for higher ranges

Measurement Area	
Measurement cell size:	0.75m
Measurement cell position:	0.35–5.0m (user selectable)
Default position (along beam):	0.35–1.85m

Doppler Uncertainty (noise)	
Typical uncertainty for default configurations:	0.5–1.0cm/s
Uncertainty in U,V at 1Hz sampling rate:	1.5cm/s

Echo intensity	
Acoustic frequency:	2MHz
Resolution:	0.45dB
Dynamic range:	90dB

Sensors	
<b>Temperature:</b>	Thermistor embedded in head
Range:	-4°C to 40°C
Accuracy/resolution:	0.1°C/0.01°C
Time response:	10 min
<b>Compass:</b>	Magnetometer
Accuracy/resolution:	2°/0.1° for tilt <20°
<b>Tilt:</b>	Liquid level
Accuracy/resolution:	0.2°/0.1°
Maximum tilt:	30°
Up or down:	Automatic detect
<b>Pressure:</b>	Piezoresistive
Range:	300m/3000m/6000m
Accuracy/resolution:	0.5% / 0.005% of full scale

Analog inputs	
Number of channels:	2
Voltage supply:	Three options selectable through firmware commands: •Battery voltage / 500 mA •+5V / 250 mA •+12V / 100 mA
Voltage input:	0–5V
Resolution:	16 bit A/D

Data communication	
I/O:	RS232, RS422. Software supports most commercially available USB–RS232 converters
Communication Baud rate:	300–115200 (baud)
Recorder download baud rate:	600/1200 k.Baud for both RS232 and RS422
User control:	Handled via Win32® software, ActiveX® function calls, or direct commands with binary or ASCII data output

Software («Aquadopp / Aquadopp DW»)	
Operating system:	Windows®XP, Windows®7
Functions:	Deployment planning, start with alarm, data retrieval, ASCII conversion. Online data collection and graphical display. Test modes

Data Recording	
Capacity:	9 MB, can add 32/176/352/MB
Data record:	40 bytes
Diagnostic record:	40 bytes

Power	
DC Input:	9–15VDC
Peak current:	3A at 12VDC (user adjustable)
Max consumption 1Hz:	0.2–1.4 W
Avg. consumption:	0.1W (0.02Hz), 0.01W (0.002Hz)
Sleep consumption:	0.0013 W
Transmitt power:	0.3–20W, 3 adjustable levels
Battery capacity:	50 Wh
New battery voltage:	13.5 Vdc
Data collection (alkaline):	6 months at 10-min, ±1.5cm/s noise
Data collection (lithium):	18 months at 10-min, ±1.5cm/s noise

Real time clock	
Accuracy:	+/- 1 min/year
Backup in absence of power:	4 weeks

Materials	
Standard:	Delrin and titanium.

Connectors	
Bulkhead (Impulse):	MCBH-8-FS, titanium
Cable:	PMCIL-8-MP on 10-m polyurethane cable

Environmental	
Operating temperature:	-5°C to 40°C
Storage temperature:	-20°C to 60°C
Shock and vibration:	IEC 721–3–2
Pressure rating:	0–300m/0–3000m/0–6000m

Dimensions			
	300m	3000m	6000m
Weight in air:	2.3kg	3.6kg	7.6kg
Weight in water:	Neutral	1.2kg	4.8kg
Cylinder:	see dimensional drawings		

Options	
Battery:	Lithium or lithium Ion
External batteries:	Alkaline, Lithium or Lithium Ion. (See battery brochure for details)
Head configuration:	Inquire

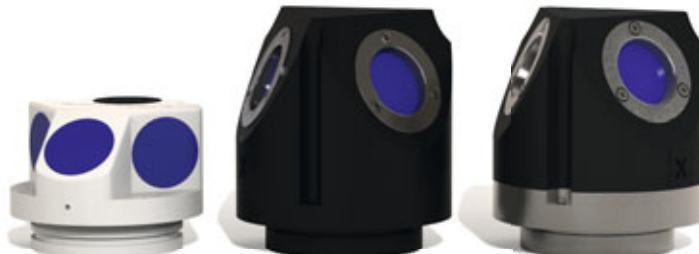

<http://www.youtube.com/NortekInfo>

<http://www.facebook.com/norteknews>

<http://twitter.com/norteknews>

TRUE INNOVATION MAKES A DIFFERENCE

NortekMed S.A.S.  
ZI Toulon Est  
67, Avenue Frédéric Joliot-Curie  
BP 520, 83078 Toulon Cedex 09  
Tel: +33 (0) 4 94 31 70 30  
Fax: +33 (0) 4 94 31 25 49  
E-mail: info@NortekMed.com

NortekUK  
Tresanton House  
Bramshott Court  
Bramshott  
Hants  
GU30 7RG, UK  
Tel: +44-1428 751 953  
E-mail: inquiry@nortekuk.co.uk

NortekUSA  
27 Drydock Avenue,  
Mailbox 32, Boston,  
MA 02210-2377  
Tel: 617-206-5750  
Tel: 617-275-8955  
Fax: 617-275-8955  
E-mail: inquiry@nortekusa.com

青岛诺泰克测量设备有限公司  
地址: 中国青岛香港西路66号  
汇鼎广场1302  
邮编: 266071  
Tel: 0532-85017570, 85017270  
Fax: 0532-85017570  
E-mail: inquiry@nortek.com.cn

Nortek B.V.  
Schipholweg 333a  
1171 PL Badhoevedorp  
Nederland  
Tel: +31 20 6543600  
Fax: +31 20 6599830  
email: info@nortek-bv.nl

Nortek Brasil  
Av. Nilo Peçanha nº 50,  
grupo 2910 – Centro - Rio de Janeiro -  
RJ – Cep 20020-906.  
Tel: +55 (21) 4126-5954  
Cel: +55 (21) 85046798  
E-Mail nortek@nortekbrasil.com.br